

USC Nuclear Engineering Education and Research

Travis W. Knight, Professor and Director
Nuclear Engineering Program
University of South Carolina
803-777-1465

twknight@sc.edu

<http://www.me.sc.edu/nuclear/index.html>

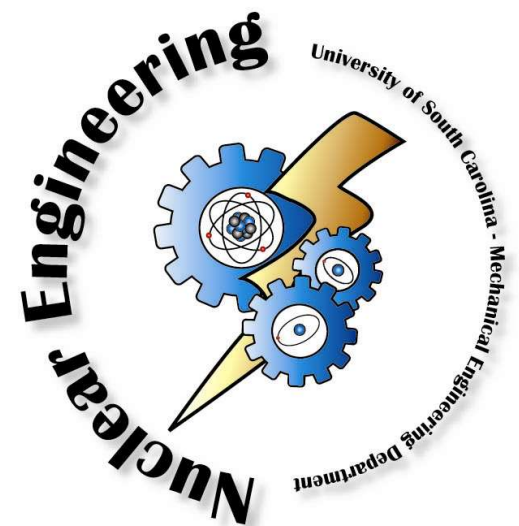

USC Nuclear Engineering Milestones

- USC began graduate nuclear engineering program (MS, PhD) in Fall 2003 in Mechanical Engineering Department
 - On campus and distance learning
- Fall 2004 hired two new tenure track faculty in addition to Mechanical Engineering faculty and adjunct faculty.
- May 2005, graduated first MS students
- December 2007, graduated first PhD
- Began an undergraduate minor in Fall 2008
- Center of Economic Excellence in Nuclear Science and Engineering awarded in 2008 by SC Research Centers of Economic Excellence
 - Endowed Chair, Dr. Dan Cacuci, hired Jan. 2012
- Additional tenure track faculty began in Fall 2009
- Center of Economic Excellence in Nuclear Science Strategies awarded in 2009 by SC Research Centers of Economic Excellence
 - Endowed Chair, Dr. Ted Besmann, hired Nov. 2014
- New Junior Faculty hired Fall 2015

More than 100 MS and PhD graduates – Summer 2017

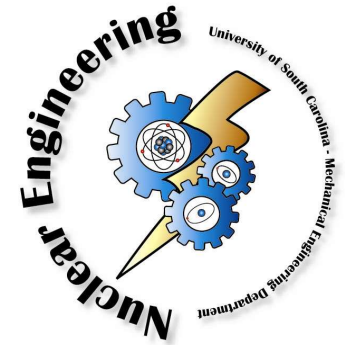

South Carolina - Nuclear Engineering

Location quotient of nuclear engineers, by state, May 2017

From: Bureau of Labor and Statistics

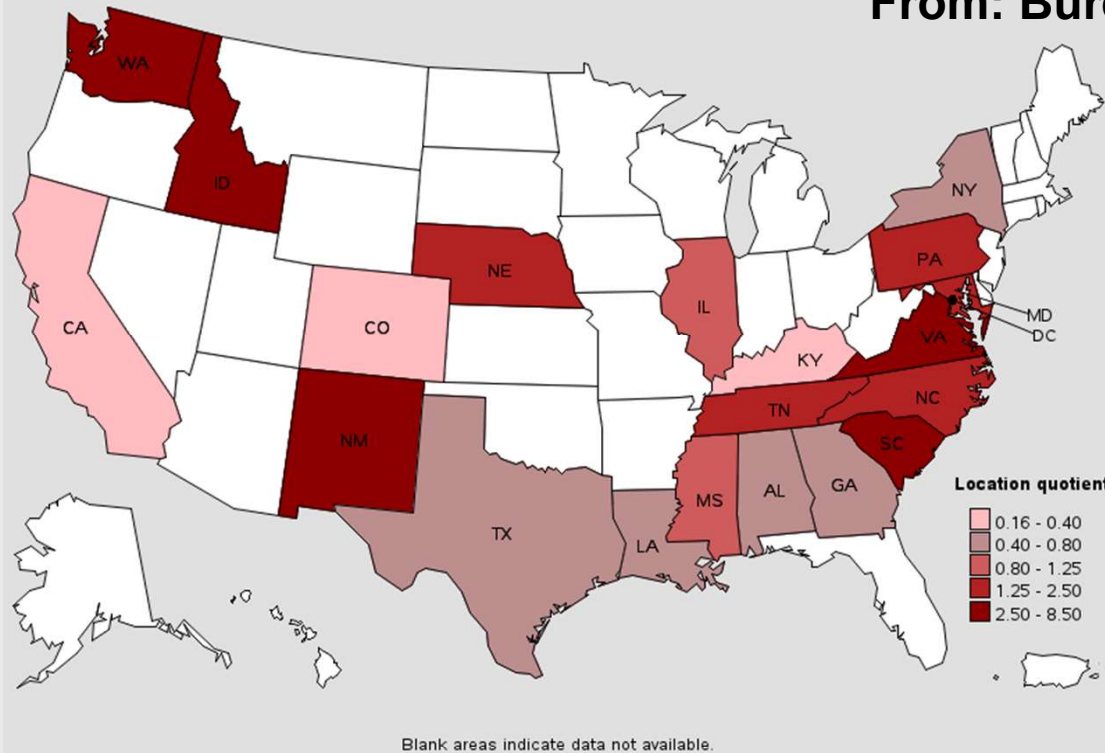

Location quotient (LQ) is a valuable way of quantifying how concentrated a particular industry, cluster, occupation, or demographic group is in a region as compared to the nation.

Annual mean wage of nuclear engineers, by state, May 2017

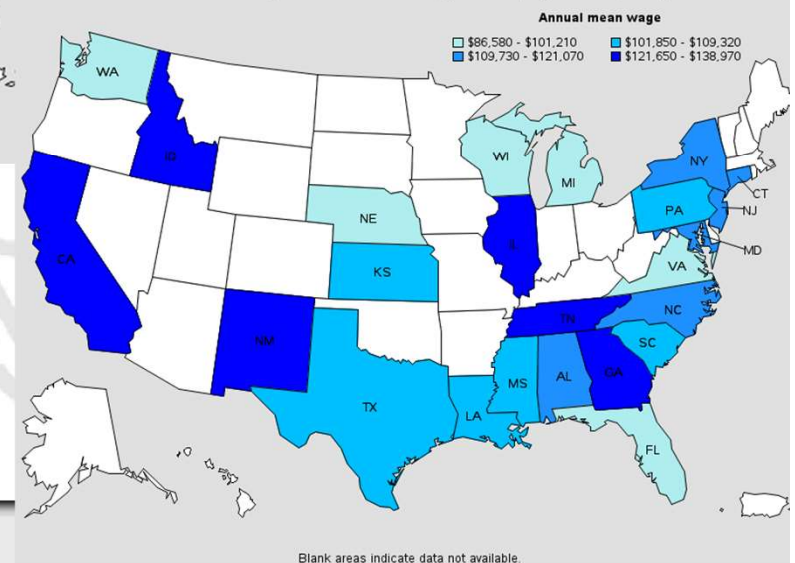

Nuclear Engineering Enrollment and Degrees Awarded

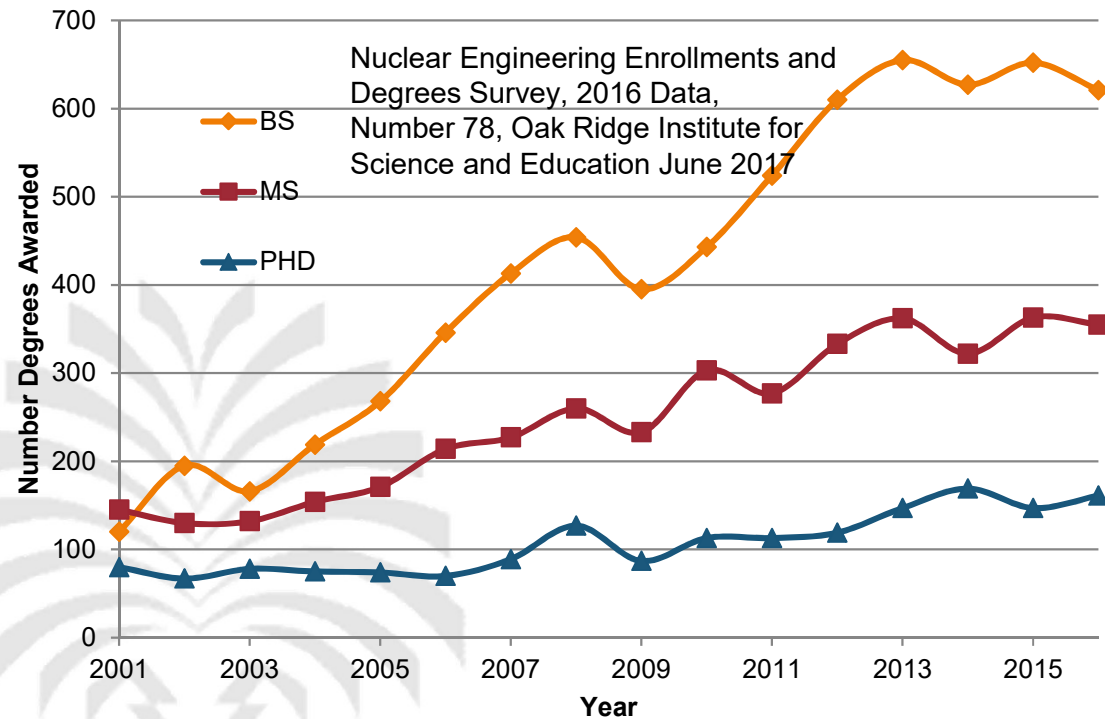

Nuclear Engineering Enrollments & Degrees Survey Data 50-Year Trend Assessment, 1966-2015, March 2017

FIGURE 2 | Nuclear Engineering Degrees, by Degree Level, 1966-2015

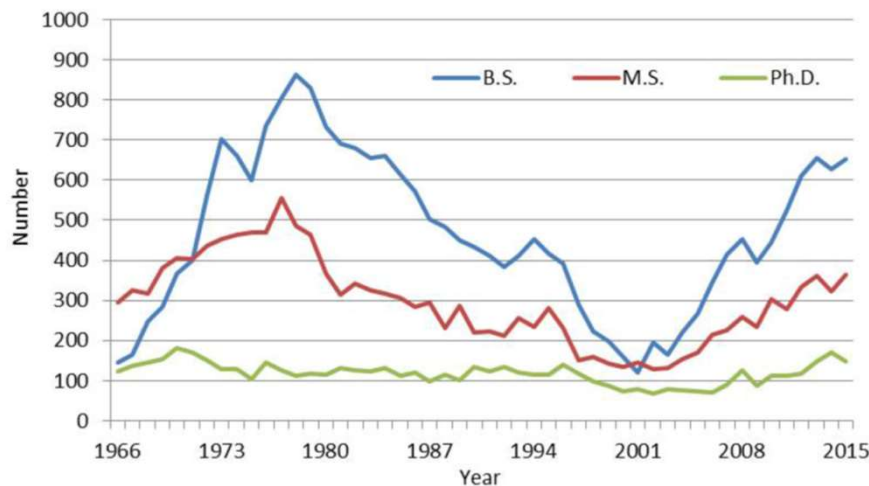

Source: Oak Ridge Institute for Science and Education.

FIGURE 1 | Nuclear Engineering Enrollment Trends, Fall 2001 – Fall 2018

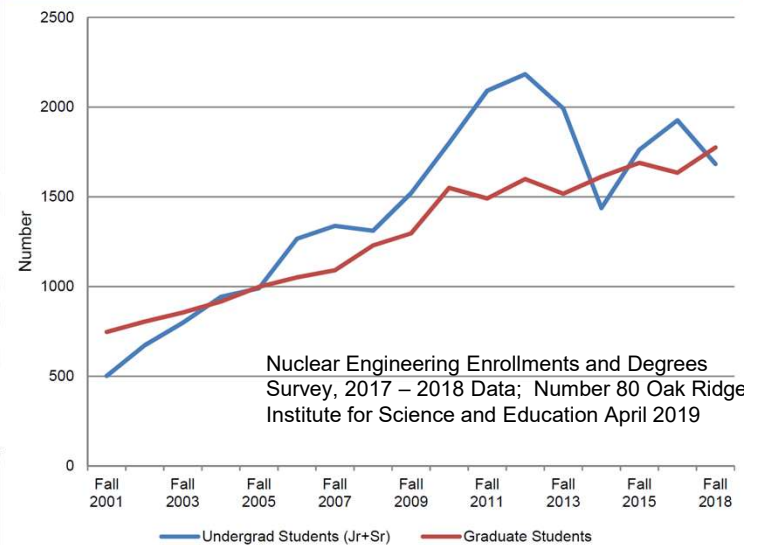

Undergraduate Minor and Graduate Nuclear Engineering Degrees and Requirements

- Undergraduate Minor – 18 credits
 - 6 nuclear engineering courses (4 core courses)
 - Able to utilize 4 undergraduate electives
- Accelerated BS/MS
 - Dual count up to 4 elective classes toward MS degree
 - Obtain MS degree in 1 additional year beyond BS
 - Thesis and Non-Thesis Options
- MS (Master's of Science) - 30 credits total
 - 6 credits from thesis research
 - 24 credits from course work (includes core courses)
- ME (Master of Engineering) - 30 credits from course work
 - includes core courses
- PhD requires additional 30 credits beyond MS/ME (60 credits beyond BS)
 - 12 credits from dissertation research
 - 18 credits from course work

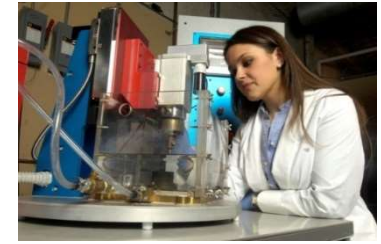
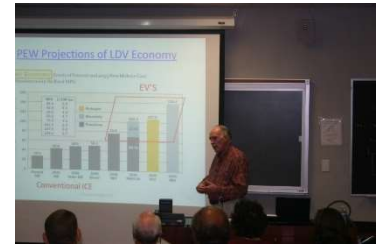

Nuclear Engineering Undergraduate Minor

- A strong emphasis on nuclear science and engineering instruction supporting energy related topics
- Required/Core Classes
 - EMCH 552: Introduction to Nuclear Engineering (Fall)
 - EMCH 553: Nuclear Fuel Cycles (Spring)
 - EMCH 557: Radiation Shielding (Fall)
 - EMCH 558: Nuclear Systems (Spring)
- Two electives (below regularly offered):
 - EMCH 556 Introduction to Risk Assessment and Reactor Safety (Fall)
 - EMCH 573 Introduction to Nuclear Materials (Fall)
 - EMCH 550 Introduction to Nuclear Safeguards (Summer)
 - EMCH 753 - Chemical Thermodynamic Calculations and Modeling with Applications (Spring)
 - EMCH 754 Thermal Hydraulic Design of Nuclear Reactors (Fall or Spring)
 - EMCH 770 Predictive Modeling: combining experiments with computations (Spring)
 - EMCH 460* Special Problems (related to NE)
*requires faculty approval and mentorship
- Additional elective options outside the College:
 - PHYS 307: Intro Modern Physics
 - PHYS 511: Nuclear Physics
- Pre-requisites:
 - CHEM 111, PHYS 211, MATH 241, MATH 242

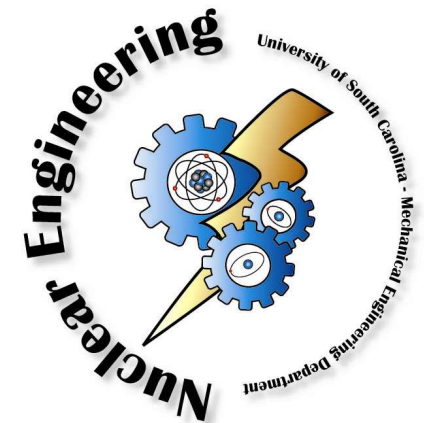

Nuclear Engineering Graduate Courses

- **Core Courses Required (4)**
 - EMCH 552 Introduction to Nuclear Engineering (Fall)
 - EMCH 553 Nuclear Fuel Cycles (Spring)
 - EMCH 758 Nuclear Systems (Spring)
 - EMCH 757 Radiation Shielding (Fall)
- **Elective Courses (at least 3 for MS or at least 5 for ME)**
 - EMCH 756 Safety Analysis for Engineering Systems (Fall)
 - EMCH 573 Introduction to Nuclear Materials (Fall)
 - EMCH 753 - Chemical Thermodynamic Calculations and Modeling with Applications (Spring)
 - EMCH 754 Thermal Hydraulic Design of Nuclear Reactors (Fall)
 - EMCH 550 Introduction to Nuclear Safeguards (Summer)
 - EMCH 755 Advanced Nuclear Engineering (Spring)
 - EMCH 770 Predictive Modeling: combining experiments with computations (Spring)
- **Engineering Elective (up to 1)**
 - Any NE elective (from above)
 - Any Engineering course at 500 level or higher.
 - i.e. EMCH 508 Finite Element
 - GEOL 650: Microscopy & Microanalysis



USC Nuclear Engineering Programs – Statistics

- USC NE program includes a strong **distance learning** component to support professionals seeking an advanced degree. Currently professionals at:
 - Utilities (SC, GA, NC), SRNL/SRS, LANL, NRC, U.S. Navy Nuclear Power School (Goose Creek, SC), Army, AFTAC, Others; formerly NASA, KAPL
- **115 graduates** have assumed variety of positions in the nuclear industry (graduates: 57 fulltime/58 part-time) since first graduates in Fall 2005:
 - Utilities, NRC, SRNL, ORNL, A/E (mostly in SC), Vendors, Fed. Gov., Academia
 - PhD=8, MS=39, ME=68
- **Enrolled (active) – 35**
 - PhD=13, MS=8, ME=14
- Undergraduates – **Minor in NE**

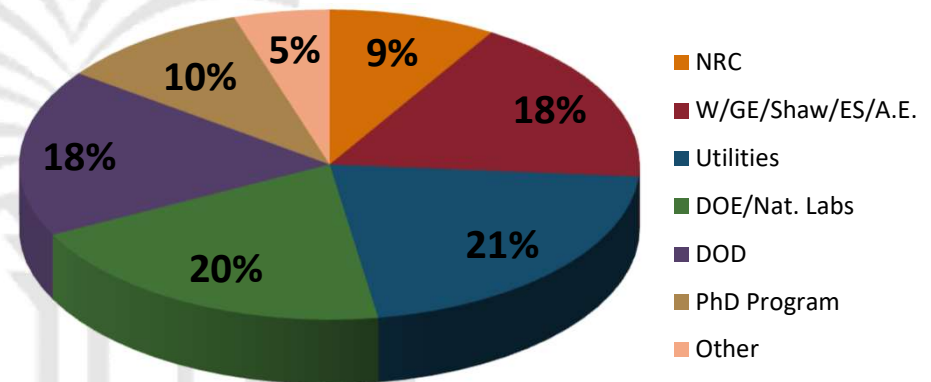

Three students placed in academia:

- **Military Academy, West Point (x2)**
- **Virginia Commonwealth University**

(*)Part-time students only counted if they took a new position in their company or changed companies upon graduation (% of total=80)

(**) students may pursue the minor and declare in their final semester



Nuclear Engineering Faculty

- Tenure Track (Teaching and Research)
 - Ted Besmann (endowed chair)
 - Dan Cacuci (endowed chair)
 - Jamil Khan
 - Travis Knight
 - Anthony Scopatz
- Adjunct and Visiting (Teaching and Research)
 - Larry Hamm (SRNL)
 - Elwyn Roberts (retired Westinghouse)
 - Val Loiselle (retired)
- Affiliated (Research, active, current)
 - Xinyu Huang (ATF cladding tests)
 - Lucy Yu (NDE used fuel canisters, gas detection in piping)
 - Paul Ziehl (concrete degradation, NDE)
- Post-Doctoral Staff
 - 11 currently

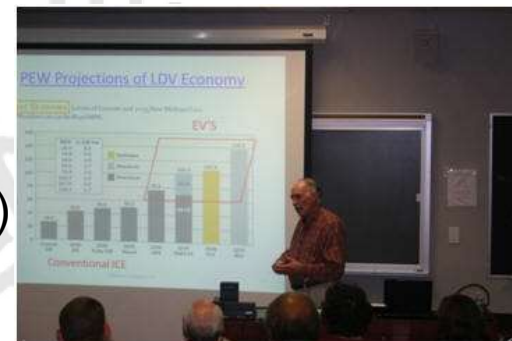

Research Highlights

- Ted Besmann – collaboration SRNL, LANL, Clemson, Westinghouse
 - Center for Hierarchical Wasteform Materials (CHWM) Energy Frontier Research Center (EFRC) H. zur Loye, Director
 - Accident tolerant fuels
- Dan Cacuci – collaboration SRNL, LANL, NNSA
 - Combine experiments with computations to reduce uncertainties in best estimate predicted model results. Improvements in models and predictions and point out importance of missing phenomena. Present methods cannot do this because of “the curse of dimensionality” i.e. number of large-scale computations increases exponentially with the number of imprecisely known parameters. Cacuci is developing “The arbitrarily high order adjoint sensitivity analysis methodology” which overcomes “the curse of dimensionality”. Cacuci’s new method increases the number of computations linearly instead of exponentially. Currently applied to LANL/SNL Pu sphere benchmark for demonstration purposes. Will be applied to detecting “needle in the haystack”.
- Travis Knight – collaboration SRNL, INL, Clemson, UF, SCSU, Westinghouse, Framatome, Orano, NRC
 - Accident tolerant fuels
 - Used fuel handling, storage, transportation.



Characterization and Drying of Oxyhydroxides on Aluminum Clad Spent Fuel

- Fuel must be dried before dry cask storage to prevent radiolytic breakdown of H_2O :
 - Free oxygen further corrodes cladding
 - Hydrogen gas problematic for later retrieval from canister
- Quantifying parameters for maximum dryness to maintain fuel integrity for future recycling:
 - Thermal Analyses
 - Scanning Electron Microscopy
 - X-Ray Diffraction
- Supported by: Savannah River National Laboratory, Project ID: LDRD-2018-00032

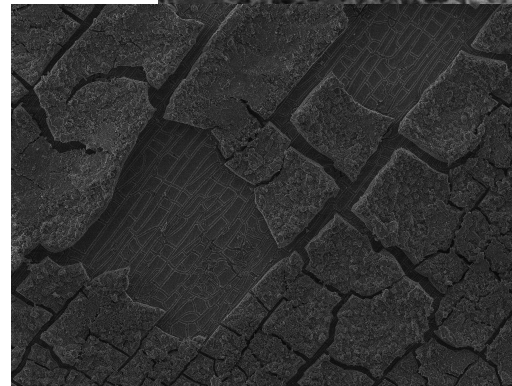
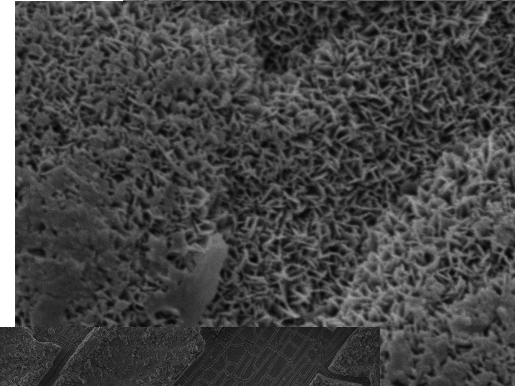
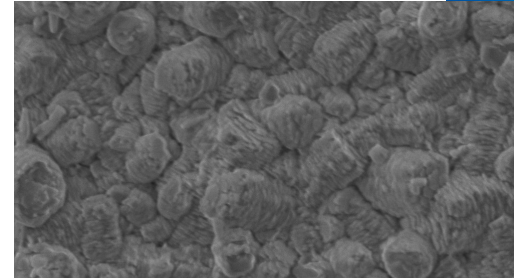
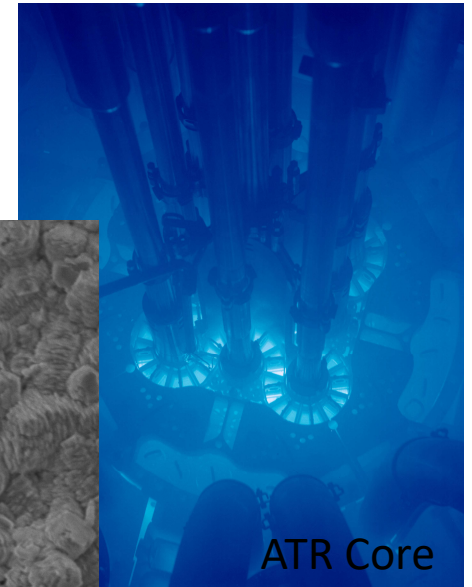

Uranium Silicide – Accident Tolerant Fuel

- U_3Si_2 is one of the advanced fuels being considered as an accident tolerant fuel (ATF)
- Changes to the fuel and cladding are being considered.
- Compression creep testing.
- Modeling in BISON, fuel performance code.
- Sponsor: DOE-NEUP

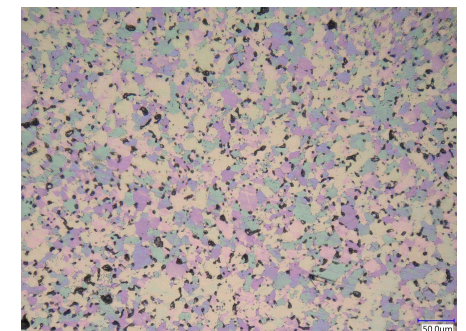
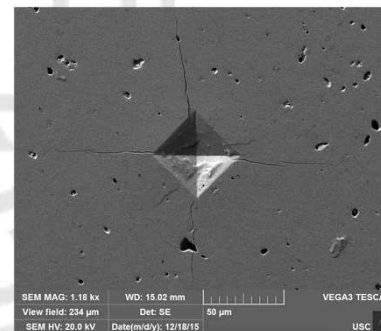
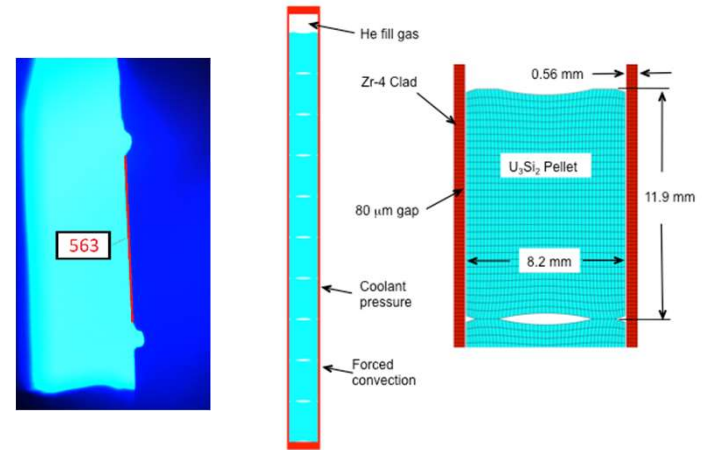

Used Fuel Drying Research

- DOE NEUP - Integrated Research Project (IRP)
- Collaboration: USC, UF, SCSU, Areva (Framatome/Orano)
- Motivation and Goals
 - Quantify water remaining in dry cask after typical industry drying operation
 - Science based understanding of the cask drying process
 - Evaluate range of conditions, features likely to encounter for storage of used fuel
 - Develop modeling tools for utilities, vendors, regulators

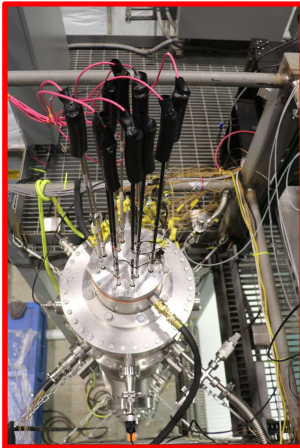

Dry Storage of Spent Fuel

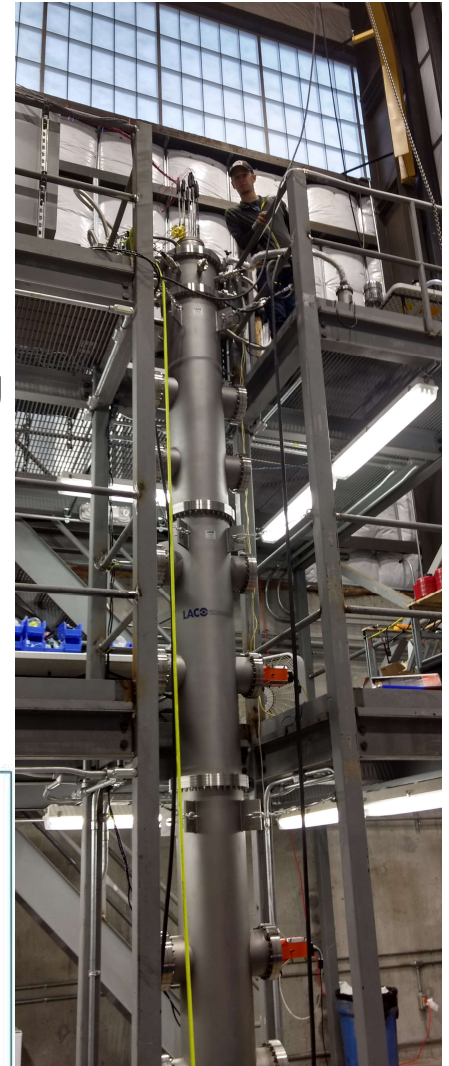
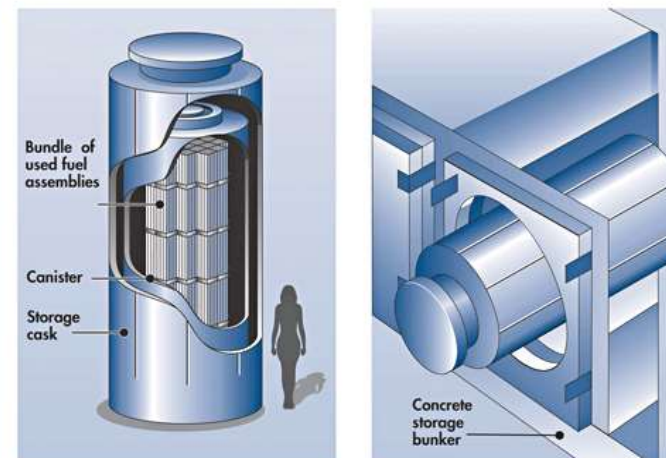

Thank You

